

Category 8 Cabling Standards Update

TIA TR42.7 Study Group for Class II Limits

Contents

1	Background	3
2	Impact of this approval on Category 7_A cabling	3
3	Differences between Class I and Class II cabling	3
3.1	Will connectors used in Class II channels be backward compatible to existing cabling?	4
3.2	Will connectors used in Class II channels be backward compatible to LAN and SAN equipment?	4
4	Category 7/7_A market share	5
5	Summary	5
6	References	6

1 Background

At the TIA TR42 plenary meeting on June 12, 2013 in Portland, Oregon, the TR42.7 formulating sub-committee approved the formation of a task group to study the concept of adding ISO/IEC TR 11801-99-1 Class II limits to the draft ANSI/TIA-568-C.2-1 Category 8 cabling standard. The study group is expected to review existing Class II specifications in teleconference calls and submit recommendations to TR42.7 at the next meetings on July 30-31, 2013 and October 8-9, 2013. This approval will allow members of TR42.7, who see advantages in PIMF cabling, an opportunity to contribute towards the development of Class II cabling specifications, as well as category 8.2 component specifications. The work in TR42.7 will have to be carefully coordinated with the ongoing work in ISO/IEC/JTC1/SC25/WG3 developing Class II specifications, IEC 46C developing Category 8.2 cable specifications, and IEC 48B developing Category 8.2 component specifications.

2 Impact of this approval on Category 7_A cabling

The formation of the study group for Class II recognizes advances in transmission technology needed for 40 G applications. TIA TR42.7 technical experts had previously rejected a proposal to develop Category 7_A cabling. The decision to develop Class II instead is further confirmation of the need for higher bandwidth and technical improvements beyond Category 7_A needed for 40 G applications.

The decision to develop Class II up to 2000 MHz is a clear indication that Category 7_A cabling specified up to 1000 MHz will not be sufficient for 40 G applications.

3 Differences between Class I and Class II cabling

The key difference between Class I and Class II cabling is the fact that Class II allows three different styles of connectors that are not compatible with one another, or with the RJ45 connector. This presents a dilemma to the customer who may not have detailed information on the advantages of each connector family. And, since the overwhelming majority of equipment ports, or MDIs, continue to use the RJ45, Class II cabling will require hybrid equipment cords. Class I, on the other hand, uses a fully backward-compatible RJ45-type interface with vastly improved performance relative to Category 6_A connectors and is specified up to 2000 MHz.

Another difference between the Category 8 cabling classes is that Class II cabling has higher NEXT and FEXT performance because each of the four pairs are individually shielded. The additional isolation provided by the shield improves NEXT and FEXT of a Category 8.2 cable by about 20 dB over Category 8.1 cable used in Class I. This difference is largely immaterial as on-board noise cancellers remove excess internal noise from the channel. The shield effectiveness can only be maintained in the channel if the connectors also have individually shielded pairs and shield continuity is maintained 360 degrees around through the connector.

3.1 Will connectors used in Class II channels be backward compatible to existing cabling?

The Class II specifications in ISO TR 11801-99-1 do not cover connector types and, by default, refer to ISO 11801 for standardized interface connectors. This means that three different types of connectors allowed in ISO 11801 and ISO 24764 data center cabling for Category 7A—including the GG45®, ARJ45®, and the TERA® connectors—are allowed in Class II. If the GG45 connector is used, Class II cabling would be backward compatible to other categories if the GG45 jack is mated to an RJ45 plug. However, the GG45 plug is not backward compatible to the RJ45 jack; so, existing cabling with RJ45 interfaces cannot be used with GG45 cords. In addition, the TERA and ARJ45 connectors allowed in the Class II standards will require the use of adapter cords to interface to existing cabling and equipment (see Figure 1 Illustration of TERA jack and ARJ45 plug showing non-compatibility to RJ45 jacks).

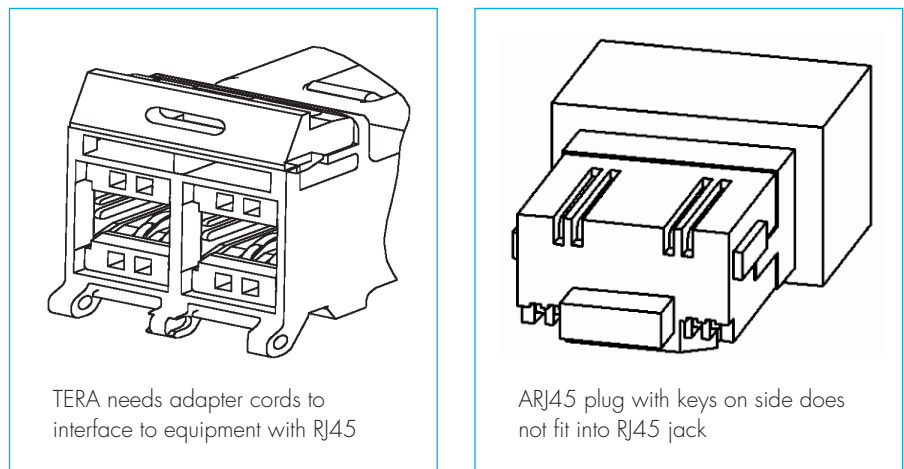

Figure 1 Illustration of TERA jack and ARJ45 plug showing non-compatibility to RJ45 jacks

3.2 Will connectors used in Class II channels be backward compatible to LAN and SAN equipment?

The three connector types allowed for Class II will need to use adapter cords when interfacing to existing equipment that use RJ45 interfaces. As shown in Figure 2: Illustration of GG45 plug from IEC 60603-7-71 standard, the GG45 system has keys on both sides of the plug with matching slots in the GG45 jack that activate a switch in the GG45 jack, allowing the connector to operate in Category 7_A mode or other category modes. Because of this backward compatibility issue and the complexity of the GG45 system, its adoption in the market will continue to be an issue when Class II is deployed in data centers that have lots of equipment with RJ45 interfaces.

TERA® is a registered trademark of The Siemon Company, and is not associated or affiliated in any way with CommScope, Inc.

ARJ45® is a registered trademark of Bel Fuse Ltd. of Hong Kong, and is not associated or affiliated in any way with CommScope, Inc.

GG45® is a registered trademark of Nexans Limited Company France and is not associated or affiliated in any way with CommScope, Inc.

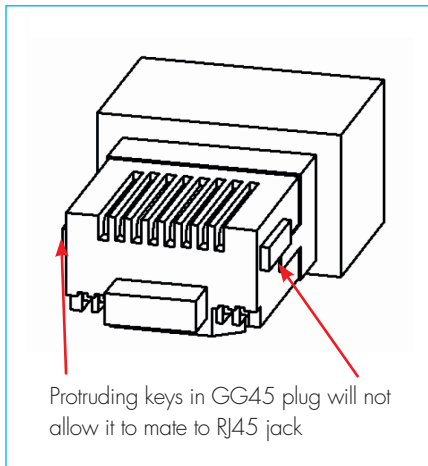

Figure 2: Illustration of GG45 plug from IEC 60603-7-71 standard

4 Category 7/7_A market share

Recent market data from BSRIA (Building Services Research and Information Association) indicates that the adoption rates of Category 7/7_A cabling and connector interfaces is expected to be around 1.5 percent of the total market in 2013, growing to just 1.9 percent of the market by 2015. In our view, this data confirms the issues that each customer and the market in general see in Category 7_A/Class F_A cabling solutions, and confirms that the market share remains low.

5 Summary

The approval of the new task group to study Class II channels is a recognition of the advances in PIMF cabling technology needed to support the use of balanced twisted copper cabling for 40 G applications. This recognition is somewhat tempered by the fact that TIA TR42.7 has to deal with the issue of three different connector types allowed for Class II. It is not clear whether TR42.7 will continue to require a single interface allowing portability and interoperability of cabling, LAN, and SAN equipment in data centers that generally use the RJ45 connector as the standard ubiquitous interface for balanced twisted pair cabling.

Recent market data from BSRIA indicates that the adoption rates of Category 7/7_A cabling will continue to remain below two percent of the total market through 2015. Our view is that this confirms the issues customers and the market in general face with Category 7_A/Class F_A cabling and may continue to haunt the market acceptance and adoption of Class II cabling. A likely reason for this poor adoption is the lack of a standardized interface connector for Class II cabling.

6 References

1. TIA TR42.7 Meeting report from Portland, Oregon, June 2013
2. BSRIA Telecommunications cabling market report, April 2013



www.commscope.com

Visit our website or contact your local CommScope representative for more information.

© 2013 CommScope, Inc. All rights reserved.

All trademarks identified by ® or ™ are registered trademarks or trademarks, respectively, of CommScope, Inc.

This document is for planning purposes only and is not intended to modify or supplement any specifications or warranties relating to CommScope products or services.

WP-107114-EN (07/13)